

质保

有关质保信息，请参阅科勒包装所附的合格证。

Warranty

For warranty information, refer to the packed KOHLER compliance certificate.

重要说明

警告:存在人身伤害风险。该产品内部有磁铁。产品应远离起搏器。

警告:存在财产受损风险。请勿将本设备暴露在阳光、火或过热的环境中。

警告:存在财产受损风险。请勿挤压、切割或将电池暴露在阳光、火或其他形式的过热环境中。

警告:存在财产受损风险。请勿将电池暴露在极低的气压下。

警告:存在财产受损风险。请勿使用输出功率大于 15 W 的充电器进行充电。

小心:存在产品损坏和人身伤害风险。产品应远离加热器。

小心:产品存在受损风险。该设备和电池的额定工作温度高达 113° F (45° C)。请勿暴露在温度可能超过 113° F (45° C) 的热源下。

小心:产品存在受损风险。该设备的短暂浸泡等级为 IPX7 级，浸入水中的时间不得超过 30 分钟。

小心:产品存在受损风险。为防止手持花洒意外脱落，请在调整手持花洒的位置之前先卸下该装置。

提示:如果使用电源适配器充电，请确保购买拥有 CCC 认证且符合标准要求的适配器。

提示:充电时，请保持设备、充电底座和线缆干燥。

为了延长电池寿命，至少每三个月完全充满一次电。电池寿命会因使用模式和环境条件而异。

IMPORTANT INSTRUCTIONS

WARNING: Risk of personal injury. The product has a magnet inside. Keep the product away from a pacemaker.

WARNING: Risk of property damage. Do not expose this device to sunlight, fire, or excessive heat of the environment.

WARNING: Risk of property damage. Do not crush, cut, or expose batteries to sunlight, fire, or other forms of excessive heat.

WARNING: Risk of property damage. Do not expose batteries to extremely low air pressure.

WARNING: Risk of property damage. Do not use chargers with output power greater than 15 W for charging.

CAUTION: Risk of product damage and personal injury. Keep the product away from the heater.

CAUTION: Risk of product damage. The device and battery are rated to operate in temperatures up to 113°F (45°C). Do not expose to heat sources where the temperature may exceed 113°F (45°C).

CAUTION: Risk of product damage. The device is rated to IPX7 for temporary immersion, and should not be submerged for more than 30 minutes.

CAUTION: Risk of product damage. To prevent accidental release from the handshower, remove the device before adjusting the handshower position.

NOTE: If charging with a power adapter, make sure to purchase the adapter that is CCC certified and meets the standard requirements.

NOTE: When charging, keep the device, charging base and cable dry.

To prolong the battery lifespan, fully charge at least once every three months. Battery life will vary due to usage patterns and environmental conditions.

规格参数

电压: 5 V

电流: 1 A

充电时间: 2.5 小时

噪音: < 72 dB

重量: 365 克 (设备: 310 克/充电底座: 55 克)

持续时间: 1.5 小时

Specifications

Voltage: 5 V

Current: 1 A

Charging time: 2.5 hours

Noise: < 72 dB

Weight: 365 g (Device: 310 g / Charging Base: 55 g)

Duration: 1.5 hours

1

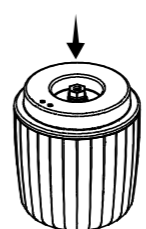

2

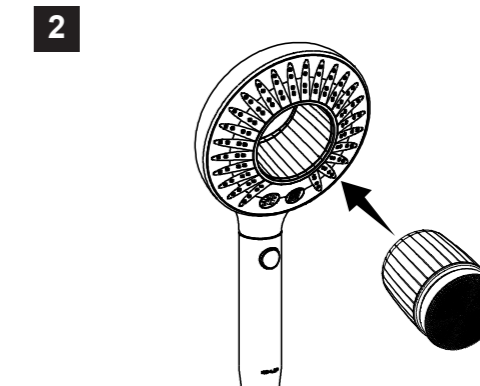

将洁面仪插入手持花洒。
Insert the cleansing device in the handshower.

根据所需的淋浴护理体验选择可灵活更换的刷头配件。将刷头连接到洁面仪上。

Select the interchangeable brush attachment based on the grooming experience required. Attach the interchangeable brush to the cleansing device.

安装说明 Installation Instructions

灵焕美妍·刷头配件套装
SpaViva All-in-One Cleansing Device
K-28683T

KOHLER

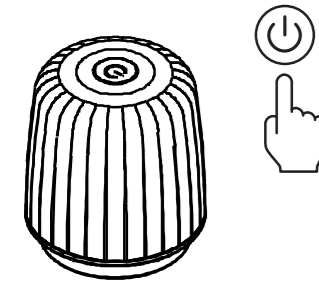

电源/配对

- 按下电源按钮一次可打开“轻柔”模式。
- 再次按下电源按钮进入“普通”模式。
- 再次按下电源按钮进入“强劲”模式。
- 再次按下电源按钮可关闭。
- 在轻柔模式和普通模式下，洁面仪将在 2 分钟后自动关闭。在强劲模式下，洁面仪将在 3 分钟后自动关闭。
- 当需要更换清洁部位时，洁面仪将每 15 秒暂停 0.5 秒。

Power/Pair

- Press the power button once to turn ON in soft mode.
- Press the power button again for normal mode.
- Press the power button again for strong mode.
- Press the power button again to turn OFF.
- The cleansing device will automatically turn OFF after 2 minutes when in soft and normal mode. In strong mode the cleansing device will automatically turn OFF after 3 minutes.
- The cleansing device will pause for 0.5 seconds every 15 seconds when the cleaning area needs to be changed.

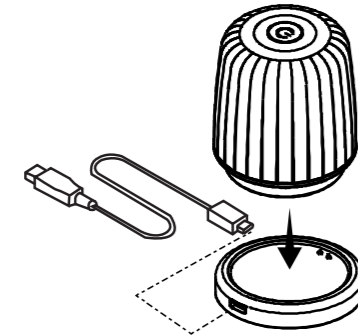

洁面仪充电

充电底座和洁面仪内部的磁铁可确保设备正确连接。

Charging of Cleansing Device

Magnet inside the charging base and the cleansing device ensures that the device connects correctly.

LED 指示灯

- **充电提示:** 充电时，白色 LED 灯每秒钟闪烁一次。充满电后，白色 LED 灯常亮。
- **电池电量不足提示 (电量低于 25%):** 每次设备打开时，白色 LED 每 10 秒快速闪烁两次。
- **没电:** 每次按下电源按钮时，白色 LED 每 5 秒快速闪烁两次。

LED Indicator

- **Charging Indication:** The white LED flashes every second while charging. The white LED glows continuously when fully charged.
- **Low Battery Indication (power less than 25%):** The white LED flashes quickly twice every 10 seconds every time the device is turned ON.
- **No Power:** The white LED flashes quickly twice every 5 seconds every time the power button is pressed.

本产品的处理要求

该产品内置锂离子可充电电池。

处理产品时，请联系您购买产品的商店或附近的政府机构，了解关于如何处理电池的指示说明。

请遵守当地法律。

在当地法律要求拆除电池的地区，将提供电池拆除说明。

部件名称	产品中有害物质或元素的名称和含量					
	铅 (Pb)	汞 (Hg)	镉 (Cd)	六价铬 (Cr (VI))	多溴联苯 (PBB)	多溴二苯醚 (PBDE)
缆线	○	○	○	○	○	○
电路板套件	X	○	○	○	○	○
塑料件	○	○	○	○	○	○
电池	○	○	○	○	○	○
其它零件	○	○	○	○	○	○

本表格按照 SJ/T 11364 的要求制作。

O: 表示该有害物质在该部件所有均质材料中的含量均在 GB/T 26572 现行有效版本规定的限量要求以下。

X: 表示材料组成中至少有某一均质材料的含量在 GB/T 26572 现行有效版本规定的限量要求以上。

 在中国销售的电子电气产品将印有“环保使用期限” (EPU) 的标志。圆圈中的数字表示正常的环保使用期限。



提示

- 在丢弃之前，任何时候都不要拆解本产品。
- 如果您需要更换电池，请联系您购买该产品的商店。锂离子电池是一种可以回收利用的宝贵资源。请帮助回收。
- 如果您有任何问题，请联系您购买该产品的商店。

Requirements for disposal of this product

This product has a built-in lithium-ion rechargeable battery.

When disposing of the product, please contact the store where you purchased the product or the nearby government agency for instructions on how to handle the battery.

Comply with local laws.

In areas where the local laws require battery removal, instructions for battery removal will be provided.

Part name	Toxic or Hazardous Substance or Elements					
	Lead (Pb)	Mercury (Hg)	Cadmium (Cd)	Hexavalent Chromium (Cr(VI))	Poly brominated biphenyls (PBB)	Poly brominated Diphenyl Ethers (PBDE)
Cable	○	○	○	○	○	○
Circuit board kit	X	○	○	○	○	○
Plastic parts	○	○	○	○	○	○
Battery	○	○	○	○	○	○
Other parts	○	○	○	○	○	○

This form is prepared in accordance with SJ / T 11364.

O: Indicates that the substance in the material composition is below the high limits of the current requirements in GB/T 26572.

X: Indicates that at least one of the homogeneous substances in the material composition is above the high limits of the current requirements in GB/T 26572.



Electronic and electrical products sold in China will be printed with the symbol of “environment protection use period” (EPU). The number in the circle represents the normal environment protection use period.



NOTE

- Do not disassemble this product at any time before discarding.
- If you need to replace the battery, contact the store where you purchased this product. The lithium-ion battery is a valuable resource that can be recycled. Help to recycle.
- If you have any questions, contact the store where you purchased this product.